

Chain Conveyor Inline 2600

Lenze Smart Products

CCI-2600



Solved with

- Shaft-mounted helical gearbox g500-S400
- Lenze Smart Motor m300-MXXMAXX 080-32

Characteristics

Application parameters		Construction data	
Maximum payload	2,600 kg	Chain acc. to DIN8187, ISO 606	10B-2
Cycle time	Up to 300 units/h	Effective circular diameter of chain pinion	91.42 mm (18 teeth)
Max. acceleration	0.5 m/s ²	Reduction gearing	1 : 1
Conveyor speed range (setting values)	0.11 – 0.5m/s (22.3 – 105 1/min)	Hollow shaft diameter	30 H7
Conveyor speed (setting values)	0.5 m/s (105 1/min)	Shaft-hub joint	Featherkey (8 ^{JS9})
Number of chain strands	2 or 3 strands	Diameter of torque plate bore hole	14 mm
		Mounting position	universal
		Weight of the drive	24.7 kg

General ambient conditions		Electromechanical properties of the drive solution	
Temperature ranges	0 – 40 °C	El. connection system • Power (type) • Control signals (type)	• 3 x 400V up to 480V (via QuickOn) • 2 x M12 (4pol, A-coded, plug)
Approvals	CE, UL, CSA, EAC, CCC	Brake resistor	integrated
Degree of protection	IP55	Electromechanical brake	none
Surface	Aluminium (unpainted)		

Chain Conveyor Inline 2600

Lenze Smart Products

Fixing dimensions

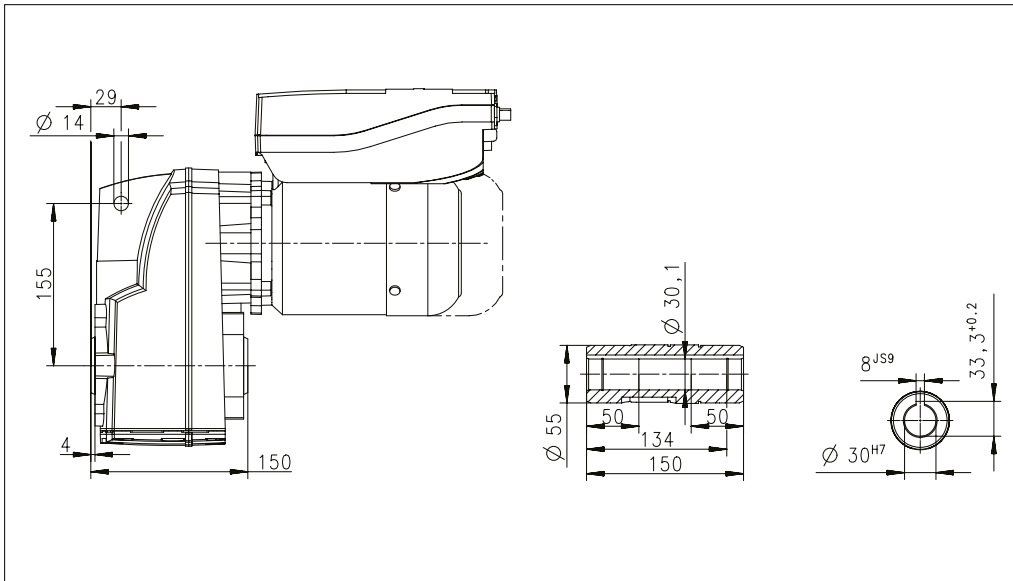

Electrical connection plan

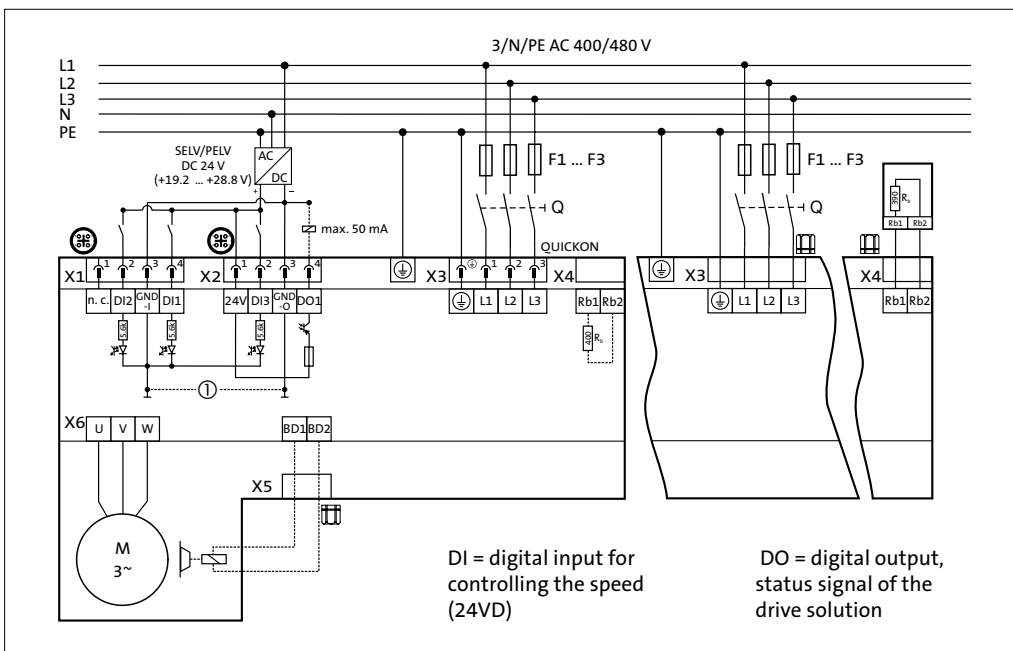

More details

CAD file	E-Plan Makro	Design basis	Mounting instructions	App Lenze Smart Motor	PC connection Lenze Smart Motor
