

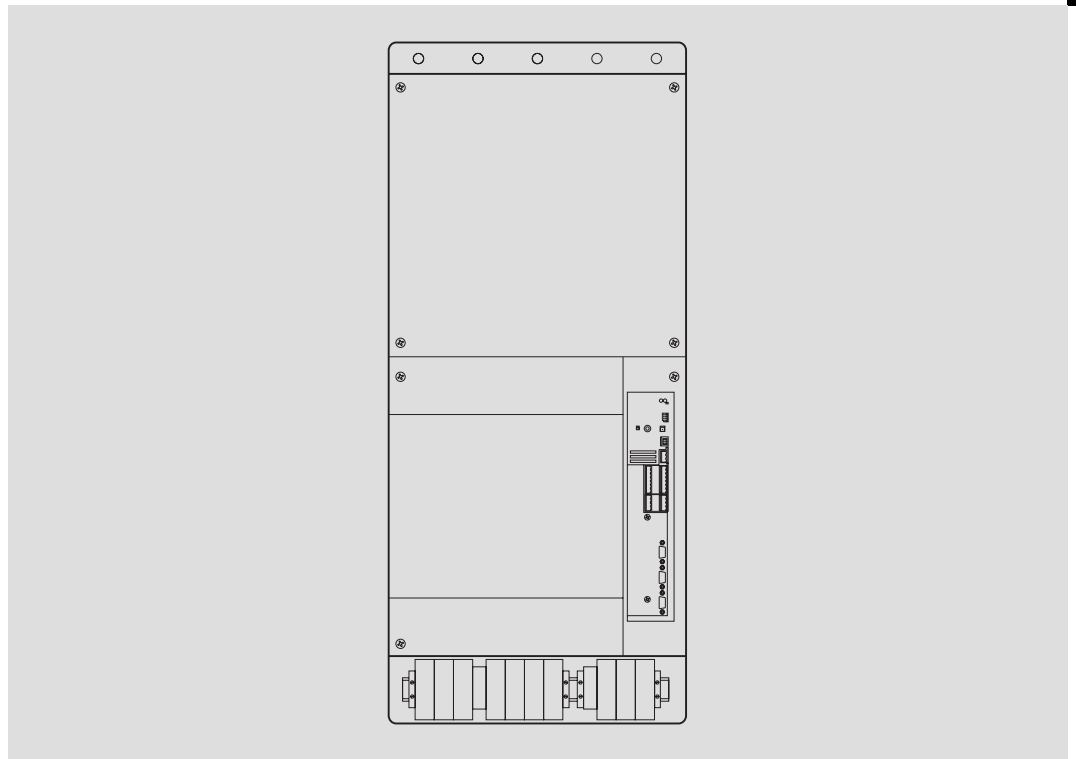

Information for the operator of the machine

9300 vector 110 ... 200 kW



EVF9335-EV ... EVF9338-EV

Frequency inverter

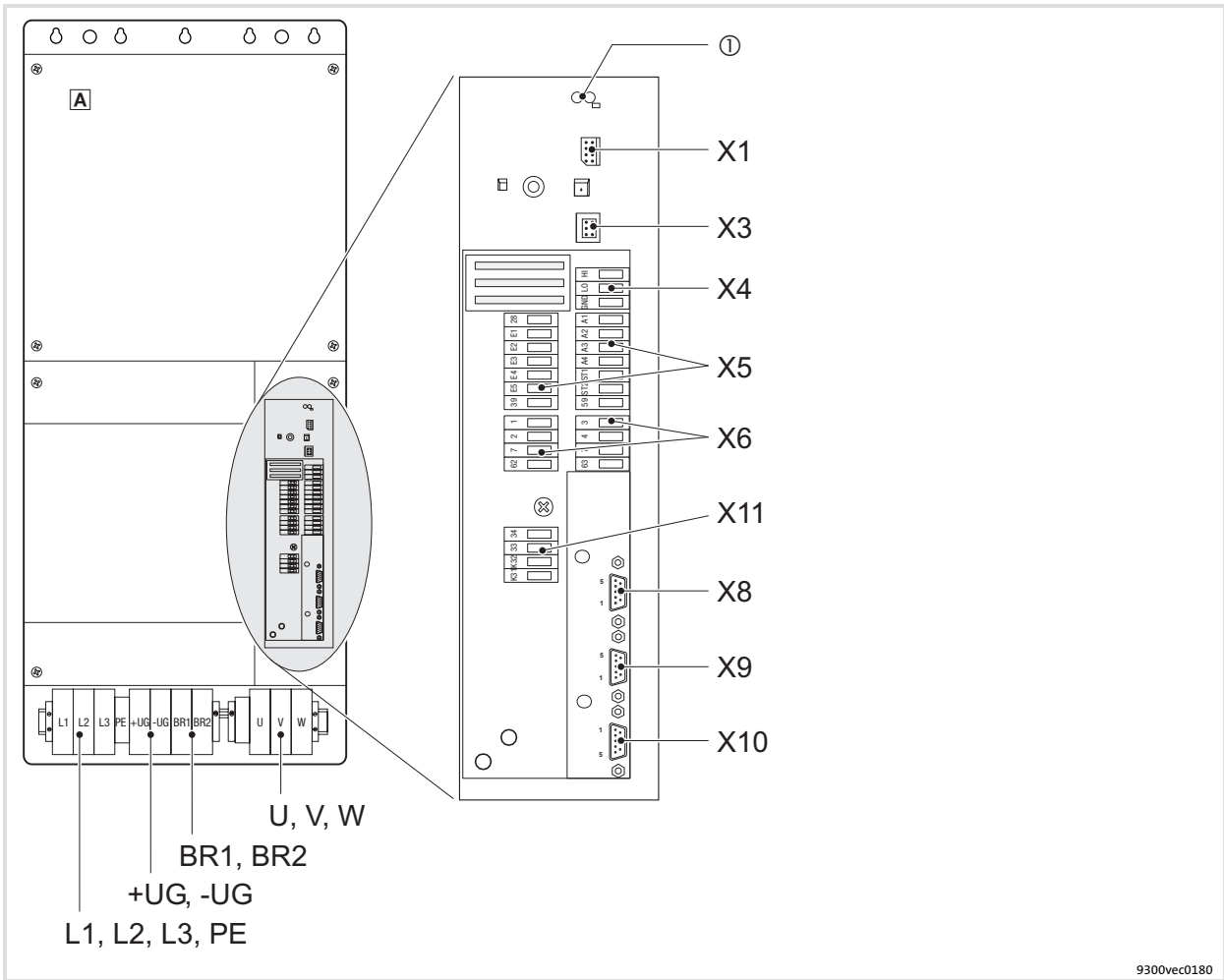

Key for overview

Position	Description
A	9300 vector frequency inverter

Connections and interfaces

Position	Description
L1, L2, L3, PE	Mains connection
+UG, -UG	DC supply (only for the variants V210, V240, V270, V300)
BR1, BR2	Connection of brake resistor (only for the variants V210, V240, V270, V300)
U, V, W, PE	Motor connection
X1	AIF interface (automation interface) slot for communication module (e.g. keypad XT EMZ9371BC)
X3	Jumper for setting the analog input signal at X6/1, X6/2
X4	Terminal strip for connection of system bus (CAN)
X5	Terminal strips for connection of digital inputs and outputs
X6	Terminal strips for connection of analog inputs and outputs
X8	Sub-D connector (male) for connection of incremental encoder with TTL level or sin/cos encoder and KTY thermal sensor of the motor
X9	Sub-D connector (male) for connection of digital frequency input signal
X10	Sub-D connector (female) for connection of digital frequency output signal
X11	Terminal strip for connection of relay output K _{SR} for "safe standstill"

Status displays

Position	LED red	LED green	Operating status
①	Off	On	Controller is enabled
	On	On	Mains is switched on and automatic start is inhibited
	Off	Blinking slowly	Controller is inhibited
	Off	On	Motor data identification is active
	Blinking quickly	Off	Undervoltage or overvoltage
	Blinking slowly	Off	Active fault

1	About this documentation	5
1.1	Document history	5
1.2	Target group	5
1.3	Validity information	6
1.4	Conventions used	7
1.5	Notes used	8
2	Safety instructions	9
2.1	General safety and application notes for Lenze controllers	9
2.2	Residual hazards	13
3	Parameter setting	14
3.1	Parameter setting with the XT EMZ9371BC keypad	14
3.1.1	General data and operating conditions	14
3.1.2	Installation and commissioning	15
3.1.3	Display elements and function keys	15
3.1.4	Changing and saving parameters	17
3.1.5	Loading a parameter set	19
3.1.6	Transferring parameters to other standard devices	20
3.1.7	Activating password protection	22
3.1.8	Diagnostics	23
3.1.9	Menu structure	24
4	Troubleshooting and fault elimination	26
4.1	Display of operating data, diagnostics	26
4.1.1	Display of operating data	26
4.1.2	Diagnostics	27
4.2	Troubleshooting	28
4.2.1	Status display via LEDs at the controller	28
4.2.2	Fault analysis with the history buffer	29
4.3	Drive behaviour in the event of faults	30
4.4	Fault elimination	31
4.4.1	Drive errors	31
4.4.2	Controller in clamp operation	32
4.5	System error messages	35
4.5.1	General error messages	35
4.5.2	Resetting system error messages	40

1 About this documentation



Note!

This documentation contains all the information required by the machine operator to run the drive controllers of the 9300 vector series installed in your machine/system.

You may make further use of the information contained in this documentation without asking Lenze for permission if you do not change the contents.

1.1 Document history

What is new / what has changed?

Materialnummer	Version			Beschreibung
13334534	2.0	04/2010	TD23	Neuaufgabe wegen Neuorganisation des Unternehmens
13238412	1.0	07/2007	TD19	Erstausgabe



Tip!

Documentation and software updates for further Lenze products can be found on the Internet in the "Services & Downloads" area under <http://www.Lenze.com>

1.2 Target group

This documentation is intended for qualified personnel according to IEC 364.

Qualified, skilled personnel are persons who have the qualifications necessary for the work activities to be undertaken during the assembly, installation, commissioning, and operation of the product.

1 About this documentation

Validity information

1.3 Validity information

... 9300 vector frequency inverters as of nameplate data:

Type	①				②	③	Nameplate
	EVF 93xx	-	x	V	Vxx	1x	
EVF 93xx	-	x	V	Vxx	Vx	6x	

Controller type

EVF Frequency inverter

Type no. / power

	400 V	500 V
9335	110 kW	132 kW
9336	132 kW	160 kW
9337	162 kW	200 kW
9338	200 kW	250 kW

Design

E Built-in unit

Version

V Vector-controlled frequency inverter

Variant

Variant	400 V	Integrated RFI filter A	
		Integrated brake transistor	
-	400 V	-	-
V030	400 V	•	-
V060	400 V	-	•
V110	400 V	•	•
V210	400 V / 500 V	-	-
V240	400 V / 500 V	•	-
V270	400 V / 500 V	-	•
V300	400 V / 500 V	•	•

Hardware version

Software version

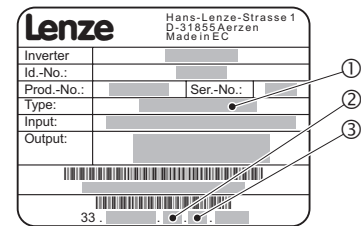

1.4 Conventions used

This documentation uses the following conventions to distinguish between different types of information:

Type of information	Identification	Examples/notes
Spelling of numbers		
Decimal separator	language-dependent	In each case, the signs typical for the target language are used as decimal separators. For example: 1234.56 or 1234,56
Warnings		
UL warnings	Ⓢ	Are only given in English.
UR warnings	Ⓡ	
Text		
Program name	» «	PC software For example: »Engineer«, »Global Drive Control« (GDC)
Icons		
Page reference	📖	Reference to another page with additional information For instance: 📖 16 = see page 16

1 About this documentation

Notes used

1.5 Notes used

The following pictographs and signal words are used in this documentation to indicate dangers and important information:

Safety instructions

Structure of safety instructions:





Danger!



(characterises the type and severity of danger)

Note

(describes the danger and gives information about how to prevent dangerous situations)

Pictograph and signal word	Meaning
 Danger!	Danger of personal injury through dangerous electrical voltage. Reference to an imminent danger that may result in death or serious personal injury if the corresponding measures are not taken.
 Danger!	Danger of personal injury through a general source of danger. Reference to an imminent danger that may result in death or serious personal injury if the corresponding measures are not taken.
 Stop!	Danger of property damage. Reference to a possible danger that may result in property damage if the corresponding measures are not taken.

Application notes

Pictograph and signal word	Meaning
 Note!	Important note to ensure troublefree operation
 Tip!	Useful tip for simple handling
	Reference to another documentation

2 Safety instructions

2.1 General safety and application notes for Lenze controllers

(in accordance with Low-Voltage Directive 2006/95/EC)

For your personal safety

Disregarding the following safety measures can lead to severe injury to persons and damage to material:

- ▶ Only use the product as directed.
- ▶ Never commission the product in the event of visible damage.
- ▶ Never commission the product before assembly has been completed.
- ▶ Do not carry out any technical changes on the product.
- ▶ Only use the accessories approved for the product.
- ▶ Only use original spare parts from Lenze.
- ▶ Observe all regulations for the prevention of accidents, directives and laws applicable on site.
- ▶ Transport, installation, commissioning and maintenance work must only be carried out by qualified personnel.
 - Observe IEC 364 and CENELEC HD 384 or DIN VDE 0100 and IEC report 664 or DIN VDE 0110 and all national regulations for the prevention of accidents.
 - According to the basic safety information, qualified, skilled personnel are persons who are familiar with the assembly, installation, commissioning, and operation of the product and who have the qualifications necessary for their occupation.
- ▶ Observe all specifications in this documentation.
 - This is the condition for safe and trouble-free operation and the achievement of the specified product features.
 - The procedural notes and circuit details described in this documentation are only proposals. It is up to the user to check whether they can be transferred to the particular applications. Lenze Automation GmbH does not accept any liability for the suitability of the procedures and circuit proposals described.
- ▶ Lenze controllers (frequency inverters, servo inverters, DC speed controllers) and the accessory components can include live and rotating parts - depending on their type of protection - during operation. Surfaces can be hot.
 - Non-authorized removal of the required cover, inappropriate use, incorrect installation or operation create the risk of severe injury to persons or damage to material assets.
 - For more information, please see the documentation.
- ▶ High amounts of energy are produced in the controller. Therefore it is required to wear personal protective equipment (body protection, headgear, eye protection, ear protection, hand guard).

Application as directed

Controllers are components which are designed for installation in electrical systems or machines. They are not to be used as domestic appliances, but only for industrial purposes according to EN 61000-3-2.

When controllers are installed into machines, commissioning (i.e. starting of the operation as directed) is prohibited until it is proven that the machine complies with the regulations of the EC Directive 98/37/EC (Machinery Directive); EN 60204 must be observed.

Commissioning (i.e. starting of the operation as directed) is only allowed when there is compliance with the EMC Directive (2004/108/EC).

The controllers meet the requirements of the Low-Voltage Directive 2006/95/EC. The harmonised standard EN 61800-5-1 applies to the controllers.

The technical data and supply conditions can be obtained from the nameplate and the documentation. They must be strictly observed.

Warning: Controllers are products which can be installed in drive systems of category C2 according to EN 61800-3. These products can cause radio interferences in residential areas. In this case, special measures can be necessary.

Transport, storage

Please observe the notes on transport, storage, and appropriate handling.

Observe the climatic conditions according to the technical data.

Installation

The controllers must be installed and cooled according to the instructions given in the corresponding documentation.

The ambient air must not exceed degree of pollution 2 according to EN 61800-5-1.

Ensure proper handling and avoid excessive mechanical stress. Do not bend any components and do not change any insulation distances during transport or handling. Do not touch any electronic components and contacts.

Controllers contain electrostatically sensitive devices which can easily be damaged by inappropriate handling. Do not damage or destroy any electrical components since this might endanger your health!

Electrical connection

When working on live controllers, observe the applicable national regulations for the prevention of accidents (e.g. VBG 4).

The electrical installation must be carried out according to the appropriate regulations (e.g. cable cross-sections, fuses, PE connection). Additional information can be obtained from the documentation.

The documentation contains information on the installation according to EMC (shielding, earthing, arrangement of filters, and installation of the cables). Also observe this information with regard to drive controllers labelled with CE marking. The manufacturer of the system or machine is responsible for the compliance of the limit values required in connection with EMC legislation. In order to observe the limit values for radio interference emissions effective at the installation site, you have to mount the drive controllers into housings (e. g. control cabinets). The housings have to enable an EMC-compliant structure. Particularly observe that, for instance, control cabinet doors preferably are metallically connected to the housing in a circumferential manner. Reduce openings or apertures through the housing to a minimum.

Lenze controllers can cause a DC current in the PE conductor. If a residual current device (RCD) is used for the protection in the case of direct or indirect contact on a three-phase supplied controller, only one residual current device of type B is permissible on the current supply side of the controller. If the controller is supplied with one phase, also a residual current device (RCD) of type A may be used. Apart from the use of a residual current device (RCD) also other protective measures can be used, like for instance isolation from the environment by double or reinforced insulation or isolation from the supply system by a transformer.

Operation

If necessary, systems including controllers must be equipped with additional monitoring and protection devices according to the valid safety regulations (e.g. law on technical equipment, regulations for the prevention of accidents). The controllers can be adapted to your application. Please observe the corresponding information given in the documentation.

After the controller has been disconnected from the supply voltage, all live components and power connections must not be touched immediately because capacitors can still be charged. Please observe the corresponding stickers on the controller.

All protection covers and doors must be shut during operation.

Notes for UL-approved systems with integrated controllers: UL warnings are notes that only apply to UL systems. The documentation contains special UL notes.

Safety functions

Special controller variants support safety functions (e.g. "safe torque off", formerly "safe standstill") according to the requirements of appendix I No. 1.2.7 of the EC Directive "Machinery" 98/37/EC, EN 954-1 category 3 and EN 1037. Strictly observe the notes on the safety functions given in the documentation on the respective variants.

Maintenance and servicing

The controllers do not require any maintenance if the prescribed operating conditions are observed.

Disposal

Recycle metals and plastics. Dispose of printed circuit board assemblies according to the state of the art.

The product-specific safety and application notes given in these instructions must be observed!

2.2 Residual hazards

Protection of persons

- ▶ Before working on the controller, check that no voltage is applied to the power terminals:
 - The power terminals U, V, W, +U_G, -U_G, BR1, BR2 and 101 ... 104 remain live for at least five minutes after disconnecting from the mains.
 - The power terminals L1, L2, L3, U, V, W, +U_G, -U_G, BR1, BR2 and 101 ... 104 remain live when the motor is stopped.
- ▶ The leakage current to earth (PE) is >3.5 mA. EN 50178 requires a fixed installation.
- ▶ The heatsink of the controller has an operating temperature of > 80 °C:
 - Direct skin contact causes burns.
- ▶ During the parameter set transfer, the control terminals of the controller can assume undefined states.
 - For this reason, the connectors X5 and X6 have to be unplugged before the transfer is executed. This ensures that the controller is inhibited and all control terminals are in the defined state "LOW".

Device protection

- ▶ Frequent mains switching (e.g. inching mode via mains contactor) can overload and destroy the input current limitation of the controller.
 - Thus, at least five minutes have to pass between two switch-on processes.
 - In case of frequent, safety-related disconnections use the "safe torque off" safety function (STO).

Motor protection

- ▶ Certain drive controller settings can overheat the connected motor:
 - E. g. long-time operation of the DC injection brake.
 - Long-time operation of self-ventilated motors at low speeds.

Protection of the machine/system

- ▶ Drives can reach dangerous overspeeds (e. g. setting of high output frequencies in connection with motors and machines not suitable for this purpose):
 - The drive controllers do not provide protection against such operating conditions. For this purpose, use additional components.

3

Parameter setting

Parameter setting with the XT EMZ9371BC keypad
General data and operating conditions

3

Parameter setting

3.1

Parameter setting with the XT EMZ9371BC keypad

Description

The keypad is available as an accessory. A full description of the keypad can be obtained from the Instructions included in the keypad delivery.

Plugging in the keypad

It is possible to plug the keypad into the AIF interface or remove it during operation.

As soon as the keypad is supplied with voltage, it carries out a self-test. The keypad is ready for operation if it is in display mode.

3.1.1

General data and operating conditions

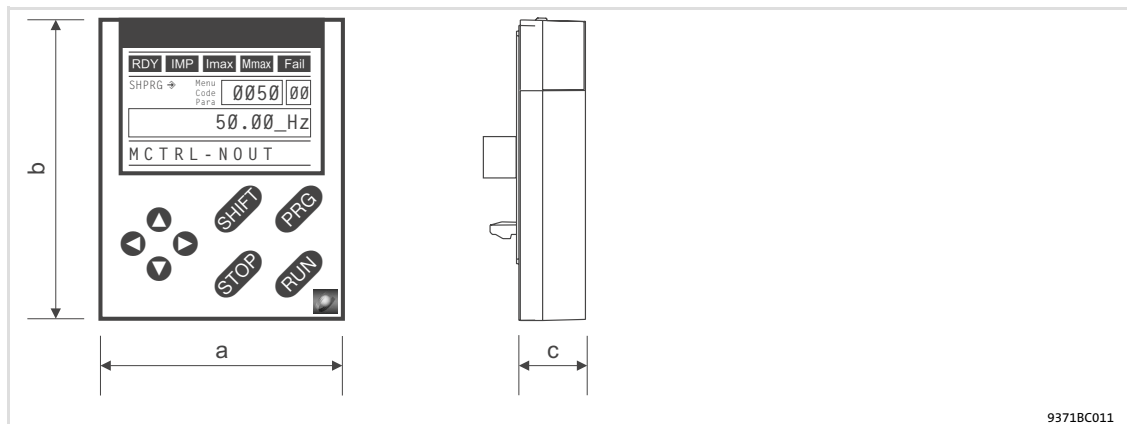

Feature	Values	
Dimensions		
Width	a	60 mm
Height	b	73.5 mm
Depth	c	15 mm
Environmental conditions		
Climate		
Storage	IEC/EN 60721-3-1	1K3 (-25 ... +60 °C)
Transport	IEC/EN 60721-3-2	2K3 (-25 ... +70 °C)
Operation	IEC/EN 60721-3-3	3K3 (-10 ... +60 °C)
Enclosure	IP 20	

3.1.2 Installation and commissioning

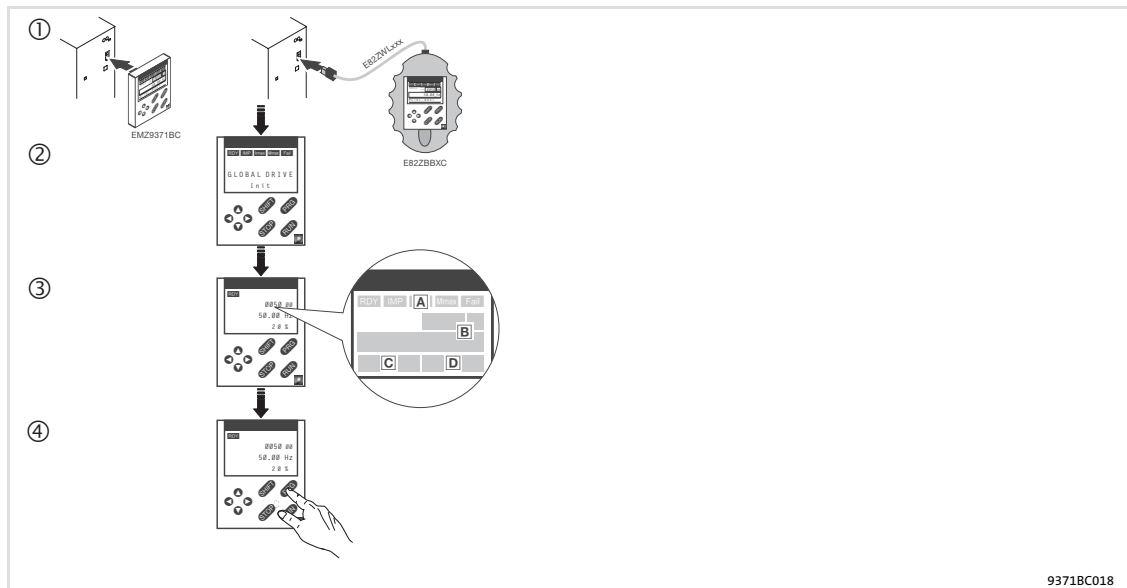

Fig. 3-1 Installation and commissioning of XT EMZ9371BC keypad or E82ZBBXC diagnosis terminal

- ① Connect keypad to the AIF interface on the front of the standard device.
The keypad can be connected/disconnected during operation.
- ② As soon as the keypad is supplied with voltage, it carries out a short self-test.
- ③ The operation level indicates when the keypad is ready for operation:
 - A Current state of the standard device
 - B Memory location 1 of the user menu (C0517):
Code number, subcode number, and current value
 - C Active fault message or additional status message
 - D Actual value in % of the status display defined in C0004
- ④ **PRG** must be pressed to leave the operation level

3.1.3 Display elements and function keys

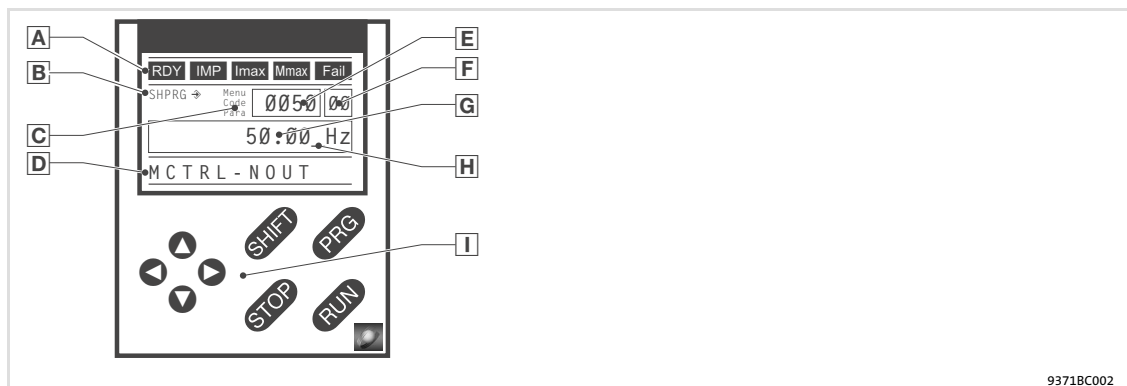

Fig. 3-2 Display elements and function keys of the XT EMZ9371BC keypad

Displays

A Status displays of standard device		
Display	Meaning	Explanation
RDY	Ready for operation	

Parameter setting

Parameter setting with the XT EMZ9371BC keypad
Display elements and function keys

IMP	Pulse inhibit is active	Power outputs are inhibited
Imax	The set current limit is exceeded in motor or generator mode	
Mmax	Speed controller 1 in the limitation	Drive is torque-controlled (Only active for operation with standard devices of the 9300 series)
Fall	Active fault	
B	Acceptance of the parameters	
Display	Meaning	Explanation
↔	Parameter is accepted immediately	Standard device operates immediately with the new parameter value
SHPRG ↔	Parameter must be acknowledged with SHIFT PRG	Standard device operates with the new parameter value after being acknowledged
SHPRG	Parameter must be acknowledged in case of controller inhibit SHIFT PRG	Standard device operates with the new parameter value after the controller is enabled again
None	Display parameter	Change is not possible
C	Active level	
Display	Meaning	Explanation
Menu	Menu level is active	Select main menu and submenus
Code	Code level is active	Select codes and subcodes
Para	Parameter level is active	Change parameters in the codes or subcodes
None	Operating level is active	Display operating parameters
D	Short text	
Display	Meaning	Explanation
alphanumeric	Contents of the menus, meaning of the codes and parameters In the operating level display of C0004 in % and the active fault	
E	Number	
Active level	Meaning	Explanation
Menu level	Menu number	Display is only active for operation with standard devices of the 8200 vector or 8200 motec series
Code level	Four-digit code number	
F	Number	
Active level	Meaning	Explanation
Menu level	Submenu number	Display is only active for operation with standard devices of the 8200 vector or 8200 motec series
Code level	Two-digit subcode number	
G	Parameter value	
	Parameter value with unit	
H	Cursor	
	In the parameter level, the digit above the cursor can be directly changed	
I	Function keys	
	For description see the following table	

Function keys



Note!

Shortcuts with **SHIFT** :
Press and hold **SHIFT**, then press the second key in addition.

Key	Function			
	Menu level	Code level	Parameter level	Operating level
PRG		Change to the parameter level	Change to the operating level	Change to the code level
SHIFT PRG	Go to the "Short setup" menu and load predefined configurations ¹⁾		Accept parameters when SHPRG ⇄ or SHPRG is displayed	
▲ ▼	Change between menu items	Change of code number	Change of digit via cursor	
SHIFT ▲ SHIFT ▼	Quick change between menu items	Quick change of code number	Quick change of digit via cursor	
▶ ◀	Change between main menu, submenu and code level		Cursor to the right Cursor to the left	
RUN	Deactivate the function of the key STOP , the LED in the key goes off			
STOP	Inhibit the controller, the LED in the key is lit. Reset fault (TRIP-Reset): 1. Remove the cause of malfunction 2. Press STOP 3. Press RUN			

¹⁾ Only active for operation with standard devices of the 8200 vector or 8200 motec series

3.1.4 Changing and saving parameters



Note!

Your settings have an effect on the current parameters in the main memory. You must save your settings in a parameter set so that they are not lost when the mains are connected.

If you only need one parameter set, save your settings as parameter set 1, since parameter set 1 is loaded automatically after mains connection.

Step	Key sequence	Action
1. Select the menu	▲ ▼ ▶ ◀	Use the arrow keys to select the desired menu
2. Change to the code level	▶	Display of the first code in the menu
3. Select code or subcode	▼ ▲	Display of the current parameter value
4. Change to the parameter level	PRG	
5. When SHPRG is displayed, inhibit the controller	STOP ¹⁾	The drive coasts
6. Change parameter	A ▶ ◀	Move cursor below the digit to be changed
	B ▼ ▲	Change of digit
	SHIFT ▼	Quick change of digit
	SHIFT ▲	
7. Accept the changed parameter		

Parameter setting

Parameter setting with the XT EMZ9371BC keypad
Changing and saving parameters

Step		Key sequence	Action
	Display of SHPRG or SHPRG →	SHIFT PRG	Confirm change to accept the parameter Display "OK"
	Display →	-	The parameter has been accepted immediately
8.	Enable the controller, if required	RUN 1)	The drive runs again
9.	Change to the code level		
	A	PRG	Display of the operating level
	B	PRG	Display of the code with changed parameter
10.	Change further parameters		Restart the "loop" with step 1. or 3.
11.	Save changed parameters		
	A	▲ ▼ ▶ ◀	Select the code C0003 "PAR SAVE" in the menu "Load/Store"
	B	PRG	Change to the parameter level Display "0" and "READY"
	C	▲	Save as parameter set 1: ⇒ Set "1" "Save PS1" Save as parameter set 2: ⇒ Set "2" "Save PS2" Save as parameter set 3: ⇒ Set "3" "Save PS3" Save as parameter set 4: ⇒ Set "4" "Save PS4"
	D	SHIFT PRG	When "OK" is displayed, the settings are permanently saved in the selected parameter set.
12.	Change to the code level		
	A	PRG	Display of the operating level
	B	PRG	Display of C0003 "PAR SAVE"
13.	Set parameters for another parameter set		Restart the "loop" with step 1. or 3.

- 1) The function of the STOP key can be programmed:
C0469 = 1: Controller inhibit
C0469 = 2: Quick stop (Lenze setting)

3.1.5 Loading a parameter set

The keypad serves to load a saved parameter set into the main memory when the controller is inhibited. After the controller is enabled, it operates with the new parameters.



Danger!

- ▶ When a new parameter set is loaded, the controller is reinitialised and acts as if it had been connected to the mains:
 - System configurations and terminal assignments can be changed. Make sure that your wiring and drive configuration comply with the settings of the parameter set.
- ▶ Only use terminal X5/28 as source for the controller inhibit! Otherwise the drive may start in an uncontrolled way when switching over to another parameter set.



Note!

- ▶ After switching on the supply voltage, the controller always loads parameter set 1 into the main memory.
- ▶ It is also possible to load other parameter sets into the main memory via the digital inputs or bus commands.

Step		Key sequence	Action
1.	Inhibit controller		Terminal X5/28 = LOW
2.	Load the saved parameter set into the main memory		
		A ▲ ▼ ▶ ◀	Select the code C0002 "PAR LOAD" in the menu "Load/Store"
		B PRG	Change to the parameter level The active parameter set is displayed, e. g. display "0" and "Load Default" If you want to restore the delivery status, proceed with D
	Select the parameter set to be loaded	C ▲	Load parameter set 1: ⇒ Set "1" "Load PS1" Load parameter set 2: ⇒ Set "2" "Load PS2" Load parameter set 3: ⇒ Set "3" "Load PS3" Load parameter set 4: ⇒ Set "4" "Load PS4"
		D SHIFT PRG	"RDY" goes off. The parameter set is loaded completely into the main memory if "RDY" is displayed again.
3.	Change to the code level		
		A PRG	Display of the operating level
		B PRG	Display of C0002 "PAR LOAD"
4.	Enable controller		Terminal X5/28 = HIGH The drive is running with the settings of the loaded parameter set

Parameter setting

Parameter setting with the XT EMZ9371BC keypad
Transferring parameters to other standard devices

3.1.6 Transferring parameters to other standard devices

Parameter settings can be easily copied from one standard device to another by using the keypad.

For this purpose use the "Load/Store" menu



Danger!

During the parameter transfer from the keypad to the standard device the control terminals can adopt undefined states!

Therefore the plugs X5 and X6 must be disconnected from the standard device before the transfer takes place. This ensures that the controller is inhibited and all control terminals have the defined state "LOW".

Copying parameter sets from the standard device into the keypad



Note!

After copying the parameter sets into the XT keypad (C0003 = 11), always the parameter set that was loaded last via C0002 is activated.

Like this the current parameters also remain active after copying:

- ▶ Save the current parameters in the parameter set before copying and load this parameter set in the controller via C0002.

Step	Key sequence	Action
1.	Connect the keypad to standard device 1	
2.	Inhibit controller	Terminal X5/28 = LOW The drive coasts.
3.	Select C0003 in the "Load/Store" menu	◀ ▶ ◀ ▶ ◀ ▶ ◀ ▶ Select code C0003 "PAR SAVE" in the "Load/Store" menu using the arrow keys.
4.	Change to the parameter level	PRG Display "0" and "READY"
5.	Copy all parameter set into the keypad	The settings saved in the keypad are overwritten. ▶ Set "11" "Save extern"
6.	Start copying	SHIFT PRG The "RDY" status display goes off. As parameter value "BUSY" is displayed. If "BUSY" goes off after approx. one minute, all parameter sets were copied into the keypad. The "RDY" status display is lit.
7.	Change to the code level	A PRG B PRG Display of the operating level Display C0003 and "PAR SAVE"
8.	Enable controller	Terminal X5/28 = HIGH
9.	Remove keypad from standard device 1	

Copying parameter sets from keypad into the standard device

Step	Key sequence	Action
1.		Connect the keypad to standard device 2
2.		Inhibit controller Terminal X5/28 = LOW The "IMP" status display is lit. The drive coasts
3.		Pull the plugs X5 and X6 All control terminals have the defined "LOW" status.
4.	◀ ▶ ▶ ▶ ▶	Select C0002 in the "Load/Store" menu Select code C0002 "PAR LOAD" in the "Load/Store" menu using the arrow keys.
5.	PRG	Change to the parameter level The active parameter set is shown, e. g. display "0" and "Load Default"
6.		Select the correct copy function The settings saved in the standard device are overwritten.
		<ul style="list-style-type: none"> Copy all parameter sets available into the EEPROM of the standard device and save them permanently. The parameter set that was active before copying is overwritten. The parameters are not yet active after copying. Select parameter set and load it in the main memory. 19
	◀	Set "20" "ext -> EEPROM"
		<ul style="list-style-type: none"> Copy individual parameter sets into the main memory of the standard device.
	◀	Copy parameter set 1 into the main memory: Set ⇒ "11" "Load ext PS1"
		Copy parameter set 2 into the main memory: Set ⇒ "12" "Load ext PS2"
		Copy parameter set 3 into the main memory: Set ⇒ "13" "Load ext PS3"
		Copy parameter set 4 into the main memory: Set ⇒ "14" "Load ext PS4"
7.	SHIFT PRG	Start copying The "RDY" status display goes off. As parameter value "BUSY" is displayed. If "BUSY" goes off, the parameter sets selected were copied into the standard device. The "RDY" status display is lit.
8.	A	Change to the code level Display of the operating level
	B	Display C0002 and "PAR LOAD"
9.	◀ ▶ ▶ ▶ ▶	<ul style="list-style-type: none"> If the function "Copy all parameter sets into the EEPROM" (C0002 = 20) is selected, they might have to be loaded in the main memory manually. If the function "Copy individual parameter sets into the main memory" (C0002 = 1x) is selected, they might have to be saved permanently in the EEPROM manually.
10.		Plug in plugs X5 and X6
11.		Enable controller Terminal X5/28 = HIGH The drive is running with the new settings.

3.1.7 Activating password protection

**Note!**

- ▶ If the password protection is activated (C0094 = 1 ... 9999), you only have free access to the user menu.
- ▶ To access the other menus, you must enter the password. By this, the password protection is annulled until you enter a new password.
- ▶ Please observe that the password-protected parameters can be overwritten as well when transferring the parameter sets to other standard devices. The password is not transferred.
- ▶ Do not forget your password! If you have forgotten your password, it can only be reset via a PC or a bus system!

Activate password protection

Step	Key sequence	Action
1. Select the "USER menu"	⬅ ➡ ⬆ ⬇	Change to the user menu using the arrow keys
2. Change to the code level	➡	Display of code C0051 "MCTRL-NACT"
3. Select C0094	⬆	Display of code C0094 "Password"
4. Change to the parameter level	PRG	Display "0" = no password protection
5. Set password		
	A ⬆	Select password (1 ... 9999)
	B SHIFT PRG	Confirm password
6. Change to the code level		
	A PRG	Display of the operating level
	B PRG	Display of C0094 and "Password"
7. Change to the "USER menu"	⬅ ⬆ ⬇	

The password protection is active now.

You can only quit the user menu if you re-enter the password and confirm it with **SHIFT PRG**.

Remove password protection

Step	Key sequence	Action
1. Change to the code level in the user menu	➡	
2. Select C0094	⬆	Display of code C0094 "Password"
3. Change to the parameter level	PRG	Display "9999" = password protection is active
4. Enter password		
	A ⬇	Set valid password
	B SHIFT PRG	Confirm The password protection is deactivated by entering the password once again.
5. Change to the code level		
	A PRG	Display of the operating level
	B PRG	Display of C0094 and "Password"

The password protection is deactivated now. All menus can be freely accessed again.

3.1.8 Diagnostics

In the "Diagnostic" menu the two submenus "Actual info" and "History" contain all codes for

- ▶ monitoring the drive
- ▶ fault/error diagnosis

In the operating level, more status messages are displayed. If several status messages are active, the message with the highest priority is displayed.

Priority	Display	Meaning
1	GLOBAL DRIVE INIT	Initialisation or communication error between keypad and controller
2	XXX - TRIP	Active TRIP (contents of C0168/1)
3	XXX - MESSAGE	Active message (contents of C0168/1)
4	Special device states:	
		Switch-on inhibit
5	Source for controller inhibit (the value of C0004 is displayed simultaneously):	
	STP1	9300 servo: Terminal X5/28 ECSxS/P/M/A: Terminal X6/SI1
	STP3	Operating module or LECOM A/B/LI
	STP4	INTERBUS or PROFIBUS-DP
	STP5	9300 servo, ECSxA/E: System bus (CAN) ECSxS/P/M: MotionBus (CAN)
	STP6	C0040
6	Source for quick stop (QSP):	
	QSP-term-Ext	The MCTRL-QSP input of the MCTRL function block is on HIGH signal.
	QSP-C0135	Operating module or LECOM A/B/LI
	QSP-AIF	INTERBUS or PROFIBUS-DP
	QSP-CAN	9300 servo, ECSxA: System bus (CAN) ECSxS/P/M: MotionBus (CAN)
7	XXX - WARNING	Active warning (contents of C0168/1)
8	xxxx	Value below C0004

3.1.9 Menu structure

For simple, user-friendly operation, the codes are clearly arranged in function-related menus:

Main menu	Submenus	Description
Display	Display	
User-Menu		Codes defined in C0517
Code list		All available codes
	ALL	All available codes listed in ascending order (C0001 ... C7999)
	PS 1	Codes in parameter set 1 (C0001 ... C1999)
	PS 2	Codes in parameter set 2 (C2001 ... C3999)
	PS 3	Codes in parameter set 3 (C4001 ... C5999)
	PS 4	Codes in parameter set 4 (C6001 ... C7999)
Load/Store		Parameter set management Parameter set transfer, restore delivery status
Diagnostic		Diagnostic
	Actual info	Display codes to monitor the drive
	History	Fault analysis with history buffer
Short setup		Quick configuration of predefined applications Configuration of the user menu The predefined applications depend on the type of the standard device (frequency inverter, servo inverter, position controller, ...)
Main FB		Configuration of the main function blocks
	NSET	Setpoint processing
	NSET-JOG	Fixed setpoints
	NSET-RAMP1	Ramp function generator
	MCTRL	Motor control
	DFSET	Digital frequency processing
	DCTRL	Internal control
Terminal I/O		Connection of inputs and outputs with internal signals
	AIN1 X6.1/2	Analog input 1
	AIN2 X6.3/4	Analog input 2
	AOUT1 X6.62	Analog output 1
	AOUT2 X6.63	Analog output 2
	DIGIN	Digital inputs
	DIGOUT	Digital outputs
	DFIN	Digital frequency input
	DFOUT	Digital frequency output
	State bus	State bus (not with 9300 frequency inverter)
Controller		Configuration of internal control parameters
	Speed	Speed controller
	Current	Current controller or torque controller
	Phase	Phase controller (not with 9300 frequency inverter)
Motor/Feedb.		Input of motor data, configuration of speed feedback
	Motor adj	Motor data
	Feedback	Configuration of feedback systems
Monitoring		Configuration of monitoring functions

Main menu	Submenus	Description
Display	Display	
LECOM/AIF		Configuration of operation with communication modules
	LECOM A/B	Serial interface
	AIF interface	Process data
	Status word	Display of status words
System bus		Configuration of system bus (CAN)
	Management	CAN communication parameters
	CAN-IN1	CAN object 1
	CAN-OUT1	
	CAN-IN2	CAN object 2
	CAN-OUT2	
	CAN-IN3	CAN object 3
	CAN-OUT3	
	Status word	Display of status words
	FDO	Free digital outputs
	Diagnostic	CAN diagnostic
FB config		Configuration of function blocks
Func blocks		Parameterisation of function blocks The submenus contain all available function blocks
FCODE		Configuration of free codes
Identify		Identification
	Drive	Software version of standard device
	Op Keypad	Software version of keypad

4 Troubleshooting and fault elimination

Display of operating data, diagnostics
Display of operating data

4 Troubleshooting and fault elimination

4.1 Display of operating data, diagnostics

4.1.1 Display of operating data

Description

Important operating parameters are measured by the controller. They can be displayed with the keypad or PC.

Some operating data can be calibrated to be displayed or selected directly with the unit of the process quantity (e.g. pressure, temperature, speed).



Note!

The calibration always affects all specified codes simultaneously.

Codes for parameter setting

Code		Possible settings			IMPORTANT
No.	Name	Lenze	Selection		
C0051	MCTRL-NACT		-36000 {1 rpm}	36000	Actual speed value, function block MCTRL <ul style="list-style-type: none">● Read only
C0052	MCTRL-Umot		0 {1 V}	800	Motor voltage, function block MCTRL <ul style="list-style-type: none">● Read only● MCTRL-VACT = 100 % = C0090
C0053	UG-VOLTAGE		0 {1 V}	900	DC-bus voltage, function block MCTRL <ul style="list-style-type: none">● Read only● MCTRL-DCVOLT = 100 % = 1000 V
C0054	Imot		0.0 {0.1 A}	5000.0	Actual motor current, function block MCTRL <ul style="list-style-type: none">● Read only● MCTRL-IACT = 100 % = C0022
C0061	Heatsink temp		0 {1 °C}	100	Heatsink temperature <ul style="list-style-type: none">● Read only● If the temperature of the heatsink > 85 °C, the controller sets TRIP <i>DH</i>● Early warning is possible via <i>DH4</i>, temperature is set in C0122
C0063	Mot temp		0 {1 °C}	200	Motor temperature <ul style="list-style-type: none">● Read only● Monitoring of the motor temperature must be activated.● KTY at X8/5, X8/8:<ul style="list-style-type: none">– At 150 °C, TRIP <i>DH3</i> is set– Early warning is possible via <i>DH7</i>, temperature is set in C0121● PTC, thermal contact at T1, T2:<ul style="list-style-type: none">– Release sets TRIP or warning <i>DH8</i>

Code		Possible settings				IMPORTANT
No.	Name	Lenze	Selection			
C0064	Utilization		0	{1 %}	150	Device utilisation I×t <ul style="list-style-type: none"> ● Read only ● Device utilisation during the last 180 s of operating time ● C0064 > 100 % releases warning 005 ● C0064 > 140 % limits the output current of the controller to 67 % of the maximum current in C0022
C0150	Status word		Bit00 – Bit01 IMP Bit02 – Bit03 – Bit04 – Bit05 – Bit06 n = 0 Bit07 CINH	Bit08 Status code Bit09 Status code Bit10 Status code Bit11 Status code Bit12 Warning Bit13 Message Bit14 – Bit15 –		Read only Decimal status word for networking via automation interface (AIF) <ul style="list-style-type: none"> ● Binary interpretation indicates the bit states

4.1.2 Diagnostics

Description

Display codes for diagnostics

Codes for parameter setting

Code		Possible settings				IMPORTANT
No.	Name	Lenze	Selection			
C0093	Drive ident					Controller identification
			0	Invalid		● Read only
			1	None		Defective power section
			14	9335VC 400V		No power section
				Display of the controller used
			20	9383VC 400V		
			21	9334VC 500V		
				
28	9383VC 500V					
9321	9321 VC					
...	...					
9333	9333VC					
C0099	S/W version		x.y		Software version	
			x	Main version	● Read only	
			y	Subversion		

4 Troubleshooting and fault elimination

Troubleshooting

Status display via LEDs at the controller

4.2 Troubleshooting

Detecting breakdowns

A breakdown can be detected quickly via the LEDs at the controller or via the status information at the keypad.

Analysing errors

Analyse the error using the history buffer. The list of fault messages gives you advice how to remove the fault. (📖 35)

4.2.1 Status display via LEDs at the controller

During operation the operating status of the controller is shown by 2 LEDs.

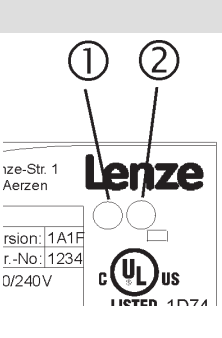
LED		Operating status	
Red ①	Green ②		
Off	On	Controller is enabled	
On	On	Mains is switched on and automatic start is inhibited	
Off	Blinking slowly	Controller is inhibited	
Off	On	Motor data identification is being performed	
Blinking quickly	Off	Undervoltage	
Blinking slowly	Off	Active fault	

4.2.2 Fault analysis with the history buffer

Retracing faults

Faults can be retraced via the history buffer. Fault messages are stored in the 8 memory locations in the order of their appearance.

The memory locations can be retrieved via codes.

Structure of the history buffer

Code			Memory location	Entry	Note
C0168/1	C0169/1	C0170/1	Memory location 1	Active fault	If the fault is no longer pending or has been acknowledged: <ul style="list-style-type: none"> • The contents of the memory locations 1 ... 7 are shifted "up" to the next memory location. • The content of memory location 8 is deleted from the history buffer and cannot be retrieved anymore. • Memory location 1 is deleted (= no active fault).
C0168/2	C0169/2	C0170/2	Memory location 2	Last fault	
C0168/3	C0169/3	C0170/3	Memory location 3	Last but one fault	
C0168/4	C0169/4	C0170/4	Memory location 4	Last but two fault	
C0168/5	C0169/5	C0170/5	Memory location 5	Last but three fault	
C0168/6	C0169/6	C0170/6	Memory location 6	Last but four fault	
C0168/7	C0169/7	C0170/7	Memory location 7	Last but five fault	
C0168/8	C0169/8	C0170/8	Memory location 8	Last but six fault	

Explanations regarding the codes

C0168	Fault indication and response <ul style="list-style-type: none"> • The entry is effected as a LECOM error number • If several faults with different responses occur at the same time: <ul style="list-style-type: none"> – Only the fault with the highest priority response is entered (1. TRIP, 2. message, 3. warning). • If several faults with the same response (e.g. 2 messages) occur at the same time: <ul style="list-style-type: none"> – Only the fault which occurred first is entered.
C0169	Time of fault occurrence <ul style="list-style-type: none"> • The reference time is provided by the power-on time meter (C0179). • If the same fault occurs several times in succession, only the time of the last occurrence is stored.
C0170	Fault frequency <ul style="list-style-type: none"> • Only the time of the last occurrence is stored.

Clear history buffer

Set C0167 = 1 to clear the history buffer.

4 Troubleshooting and fault elimination

Drive behaviour in the event of faults
Fault analysis with the history buffer

4.3 Drive behaviour in the event of faults

The controller responds differently to the three possible fault types TRIP, message, or warning:

TRIP

TRIP (display in keypad XT:  )

- ▶ Switches the power outputs U, V, W to a high-resistance state until TRIP reset is executed.
- ▶ The fault indication is entered into the history buffer as "current fault" in C0168/1.
- ▶ The drive coasts without any control!
- ▶ After TRIP reset ( 40):
 - The drive travels along the ramps to its setpoint.
 - The fault indication is moved to C0168/2 as "last fault".

Messages

Message (display in keypad XT:  )

- ▶ Switches the power outputs U, V, W to a high-resistance state.
- ▶ The fault indication is entered into the history buffer as "current fault" in C0168/1.
- ▶ In case of a fault ≤ 5 s:
 - The drive coasts without any control as long as the message is active!
 - If the message is not active anymore, the drive travels to its setpoint with maximum torque.
- ▶ In case of a fault > 5 s:
 - The drive coasts without any control as long as the message is active!
 - If the message is not active anymore, the drive travels to its setpoint along the adjusted ramps.
- ▶ If the message is not active anymore, the fault indication is moved to C0168/2 as "last fault".

Warnings

"Heatsink overtemperature" (keypad XT:   )

- ▶ The drive continues to travel in a controlled way!
- ▶ The warning signal goes off when the fault is not active anymore.

"Error in motor phase" (keypad XT: )

"PTC monitoring" (keypad XT: )

- ▶ The drive continues to travel in a controlled way!
- ▶ The fault indication is entered into the history buffer as "current fault" in C0168/1.
- ▶ After TRIP reset, the fault indication is moved to C0168/2 as "last fault".

4.4 Fault elimination

4.4.1 Drive errors

Malfunction	Cause	Remedy
An asynchronous motor with feedback rotates in an uncontrolled manner and with low speed	<p>The motor phases are reversed so that the rotating field of the motor is not identical with the rotating field of the feedback system. The drive shows the following behaviour:</p> <ul style="list-style-type: none"> • V/f characteristic control (C0006 = 5) <ul style="list-style-type: none"> – The motor rotates faster than the speed setpoint by the value set in C0074 (influence of the speed controller, Lenze setting 10 % of n_{max}). After the controller is enabled, it does not stop at zero speed setpoint or quick stop (QSP). – The final motor current depends, among other things, on the set value of the V_{min} boost (C0016) and can rise to I_{max} (C0022). This may activate the fault message OC5. • Vector control (C0006 = 1) <ul style="list-style-type: none"> – The motor rotates slowly with maximum slip speed (depending on motor data and maximum current) and does not react to a speed setpoint. The direction of rotation, however, is determined by the sign of the speed setpoint. – The motor current rises up to I_{max} (C0022). This may activate the fault message OC5 with a time delay. 	<ul style="list-style-type: none"> • Check motor cable for correct phase relation. • If possible, operate the motor with deactivated feedback (C0025 = 1) and check the direction of rotation of the motor.
Motor does not rotate although the controller is enabled (IMP is off) and a speed setpoint has been specified.	The two terminal strips X5 are reversed. Since X5/A1 and X5/28 face each other, the controller can be enabled if the control terminals are internally supplied. All other connections, however, are assigned incorrectly so that the motor cannot start.	<p>Check the position of the terminal strips:</p> <ul style="list-style-type: none"> • If you look at the connection unit in reading direction, the left terminal strip X5 must be connected with the input signals and the right terminal strip X5 must be connected with the output signals.
The monitoring of the motor phases (LP1) does not respond if a motor phase is interrupted, although C0597 = 0 or 2	The function block MLP1 is not entered into the processing table.	Enter the function block MLP1 into the processing table. The function block MLP1 requires 30 μ s of calculating time.
If during high speeds DC-injection braking (GSB) is activated, the fault OC1 (TRIP) or OU (TRIP) occurs	During DC-injection braking the controller sets pulse inhibit for a short time (DCTRL-IMP) to reduce the magnetisation in the motor before a DC voltage is injected into the motor. At high speeds (e. g. in case of mid-frequency motors) the residual voltage which develops from the residual magnetism and high speed can generate such a high motor current that OC1 or OU are activated.	<p>Prolong the duration of the pulse inhibit:</p> <ul style="list-style-type: none"> • Connect the output signal DCTRL-IMP to the function block TRANSx and adjust the desired switch-off time there (usually 500 ms). If DCTRL-CINH1 is set to HIGH, the duration of the pulse inhibit is prolonged by the time adjusted.

4 Troubleshooting and fault elimination

Fault elimination Controller in clamp operation

4.4.2 Controller in clamp operation

The clamp operation is a permissible operating mode. But since, however, pulse inhibit is set again and again, the controller cannot provide the optimum power.

If the output power is optimal, the output current mainly is right below the clamp threshold.

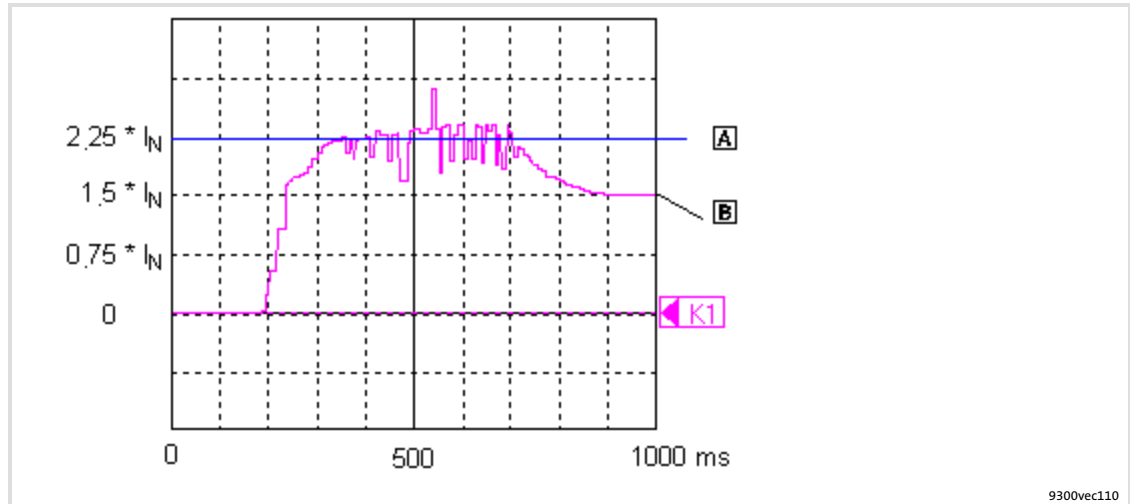

Fig. 4-1 Output current when starting a motor with high load (shown with the oscilloscope in GDC)

- A** Clamp threshold
- B** Output current

Function

1. When the output current reaches $2.25 \times I_r$, a software clamp is activated.
2. The controller sets pulse inhibit for a short time. The motor current decreases as a function of the inductance in the motor circuit.
 - An internal counter is increased by the value one.
3. After max. $250 \mu\text{s}$ the pulse inhibit is deactivated.
4. If a software clamp reoccurs within 2 s, the internal counter is again increased by the value one. Otherwise the counter is set to zero.
 - If the counter reaches the value 4300, OC3 (TRIP) is activated.

If the DC-bus voltage (U_{DC}) exceeds the switch-off threshold OU, pulse inhibit will be set. At the same time, an internal timer for a delay time (C0912) will be started.

Pulse inhibit will be reset, if the voltage falls below the switch-on threshold OU and the delay time has elapsed.

Thresholds for DC-bus overvoltage (OU)

Types EVF93xx-EVV210, EVF93xx-EVV240, EVF93xx-EVV270 and EVF93xx-EVV300				
Mains voltage range		C0173	Switch-off threshold OU	Switch-on threshold OU
< 400 V	Operation with or without brake transistor	0	770 V	755 V
400 V	Operation with or without brake transistor	1 *	770 V	755 V
460 V	Operation with or without brake transistor	2	770 V	755 V
480 V	Brake transistor	3	770 V	755 V
480 V	Brake transistor	4	800 V	785 V
500 V	Operation with or without brake transistor	5	900 V	885 V

* Lenze setting

Types EVF93xx-EV, EVF93xx-EVV060 and EVF93xx-EVV110				
Mains voltage range		C0173	Switch-off threshold OU	Switch-on threshold OU
400 V	Operation with or without brake transistor	Read only	700 V	685 V

Codes for parameter setting

Code		Possible settings		IMPORTANT
No.	Name	Lenze	Selection	
C0912	OV delay time	→	{1 ms}	- Delay time of the pulse enable after an OU message → Depending on C0082, C0086, C0087, C0088, C0089, C0090, C0091, C0092 A change of one of the codes resets C0912 to the time of the selected motor • The time is derived from the double rotor time constant

Adjustment

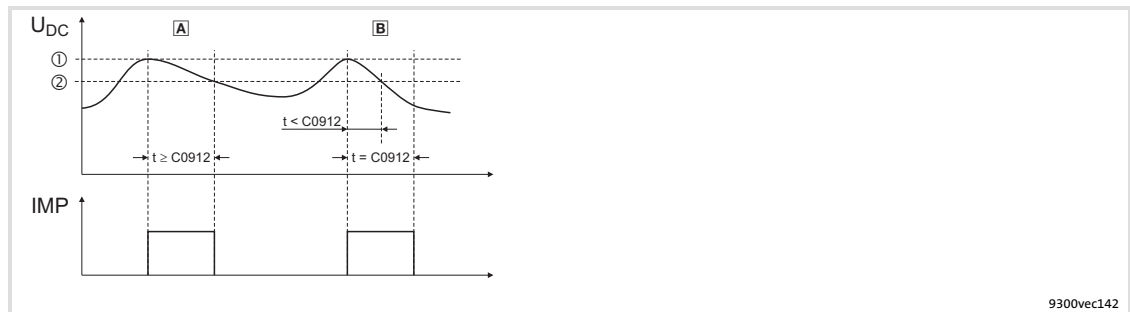

Fig. 4-2 Influence of the delay time (C0912)

① Switch-off threshold OU

② Switch-on threshold OU

A The period of time between exceeding the switch-off threshold OU and undershooting the switch-on threshold OU equals or is higher than the delay time set in C0912.

After undershooting the switch-on threshold OU, the pulse inhibit is deactivated.

B The period of time between exceeding the switch-off threshold OU and undershooting the switch-on threshold OU is lower than the delay time set in C0912.

The pulse inhibit is deactivated after the delay time in C0912 has elapsed.

- ▶ The delay time in [ms] is set under C0912. The Lenze setting can be changed by the factor 0.5 ... 2.

4.5 System error messages

4.5.1 General error messages



Note!

If you use GDC or a fieldbus module to retrieve the fault (C0168/x), the error message will be represented by an error number.

Display	Error number x = 0: TRIP x = 1: Message x = 2: Warning	Error	Cause	Remedy
---	---	No fault	—	—
CCr	x071	System fault	Processor is overloaded or there is a fault in the program processing	Reduce processor load. Remove function blocks that are not needed from the processing table
			Strong interference on control cables	Shield control cables
			Ground or earth loops in the wiring	Check wiring
CE0	x061	Communication error	Fault during transmission of control commands via automation interface X1	Plug in automation module firmly, bolt down, if necessary
CE1	x062	Communication error at the process data input object CAN-IN1	CAN-IN1 object receives faulty data, or communication is interrupted	<ul style="list-style-type: none"> • Check cable at X4 • Check sender • Increase monitoring time under C0357/1 if necessary
CE2	x063	Communication error at the process data input object CAN-IN2	CAN-IN2 object receives faulty data, or communication is interrupted	<ul style="list-style-type: none"> • Check cable at X4 • Check sender • Increase monitoring time under C0357/2 if necessary
CE3	x064	Communication error at the process data input object CAN-IN3	CAN-IN3 object receives faulty data, or communication is interrupted	<ul style="list-style-type: none"> • Check cable at X4 • Check sender • Increase monitoring time under C0357/3 if necessary
CE4	x065	BUS-OFF state	Controller has received too many incorrect telegrams via system bus X4, and has disconnected from the bus	<ul style="list-style-type: none"> • Check wiring • Check bus termination (if any) • Check shield contact of the cables • Check PE connection • Check bus load • Reduce baud rate (observe cable length)
EEr	x091	External fault (TRIP-Set)	A digital input assigned with TRIP-set function has been activated (in the most basic configurations the input X5/E4 is LOW-active and linked with the TRIP-set function)	<ul style="list-style-type: none"> • Check external encoder • Check signal at the digital input X5/E4: <ul style="list-style-type: none"> – Either connect HIGH level or – Change polarity in C0114 to HIGH-active. CAUTION! When changing to HIGH level, the wire-break protection gets lost.
			The two terminal strips at X5 are reversed	Check the position of the terminal strips: <ul style="list-style-type: none"> • If you look at the connection unit in reading direction, the left terminal strip X5 must be connected with the input signals and the right terminal strip X5 must be connected with the output signals.
H05	x105	Internal fault		Contact Lenze
H07	x107	Wrong power stage	During initialisation of the controller, a wrong power stage was detected	Contact Lenze

4

Troubleshooting and fault elimination

System error messages

General error messages

Display	Error number x = 0: TRIP x = 1: Message x = 2: Warning	Error	Cause	Remedy
H10	x110	Sensor fault - heatsink temperature	Sensor of the heatsink temperature detection indicates undefined values	Contact Lenze <ul style="list-style-type: none"> Fault message can only be reset by mains switching
H11	x111	Sensor fault - temperature inside the device	Sensor of the internal temperature detection indicates undefined values	Contact Lenze <ul style="list-style-type: none"> Fault message can only be reset by mains switching
ID1	x140	Error during motor data identification	<ul style="list-style-type: none"> No motor connected Stator resistance too high Controller inhibited externally 	<ul style="list-style-type: none"> Check motor connection Check motor data entry Enable controller and repeat motor data identification. The controller enable must be pending continuously until the end of the identification process.
ID2	x141	Error during motor data identification	Motor too small	<ul style="list-style-type: none"> Check entered motor data – When setting parameters with Global Drive Control, use the input assistant for motor data The measurements for the inverter error characteristic and the stator resistance are correct (save measured values in C0003). In the operating mode U/f characteristic control, the motor data identification can be completed.
			Controller inhibited externally	Enable controller and repeat motor data identification. The controller enable must be pending continuously until the end of the identification process.
LP1	x032	Motor phase failure	A current-carrying motor phase has failed	<ul style="list-style-type: none"> Check motor Check supply cables
			The current limit is set too high	Set a lower current limit value under C0599
			This monitoring is not suitable for field frequencies >480 Hz and synchronous servo motors	Deactivate monitoring with C0597= 3
LU	x030	Undervoltage	DC bus voltage is smaller than the value set under C0173	<ul style="list-style-type: none"> Check mains voltage Check supply module
NMAX	x200	Maximum system speed exceeded (C0596)	Active load too high	Check drive dimensioning
			Drive is not speed-controlled, torque excessively limited	If required, increase torque limit
			Current speed is detected incorrectly	Check parameter setting of the incremental encoder (C0025)
OC1	x011	Overcurrent (motor current > 2.25-fold rated controller current, hardware monitoring)	Short circuit/earth fault	<ul style="list-style-type: none"> Remove cause of short circuit/earth fault Check motor and cable If required, measure the insulation resistance
			Capacitive charging current of the motor cable too high (especially with lower powers)	Use shorter or low-capacitance motor cable
			Acceleration/deceleration times too short in proportion to the load (C0012, C0013, C0105)	<ul style="list-style-type: none"> Increase the gain (P component) of the current controller (C0075) Reduce integral-action time (integral action component) of the I_{max} controller (C0076)

Display	Error number x = 0: TRIP x = 1: Message x = 2: Warning	Error	Cause	Remedy
			<p>The drive is connected to the coasting machine. The coasting is caused by a short-time pulse inhibit, e.g. at</p> <ul style="list-style-type: none"> ● OU (overvoltage in the DC bus) ● external or internal controller inhibit 	<ul style="list-style-type: none"> ● Activate flying restart circuit ● Operate with speed feedback in the vector control operating mode
			<ul style="list-style-type: none"> ● Encoder error ● Tracks for encoder feedback of the motor speed are reversed 	<ul style="list-style-type: none"> ● Check wiring of the encoder ● In case of drive problems with activated feedback, the feedback can be analysed. Here, the signal of the feedback is not used for control. For this test the function block DFIN must be entered into the processing table. In the Lenze setting, DFIN is entered at position 1 of the processing table (C0465/1 = 200). <ul style="list-style-type: none"> – Deactivate feedback with C0025 = 1 – Connect feedback at the digital frequency input DFIN (X9) – Set DFIN constant (C0425) to the number of increments of the encoder – In C0426, the speed detected by the encoder is indicated
			DC-injection braking at high speeds	<ul style="list-style-type: none"> ● See 31
OC2	x012	Earth fault	<p>One of the motor phases has earth contact</p> <p>Excessive capacitive charging current of the motor cable</p>	<ul style="list-style-type: none"> ● Check motor ● Check supply cables <p>Use motor cable which is shorter or of lower capacitance</p>
OC3	x013	Overload during acceleration	Acceleration/deceleration times too short in proportion to the load (C0012, C0013, C0105)	<ul style="list-style-type: none"> ● Increase the gain (P component) of the current controller (C0075) ● Reduce integral-action time (integral action component) of the I_{max} controller (C0076) ● Increase ramp times ● 32, "controller in clamp operation (fault OC3)"
OC5	x015	$I \times t$ overload	<p>The utilisation of the controller exceeds 100 % (C0064 > 100 %)</p> <p>The utilisation of the controller exceeds 110 % (C0064 > 110 %)</p> <ul style="list-style-type: none"> ● The maximum current is reduced <p>Reversed motor phases when operating with feedback or reversed encoder tracks so that the direction of rotation has changed</p>	<p>Check drive dimensioning</p> <ul style="list-style-type: none"> ● The utilisation of the controller is calculated from the mean value of the motor current over a time of 180 s. When operating with rated power (150 % overload capacity), the controller can be operated at a utilisation of up to 100 %. ● When C0064 = 95 %, the warning is cancelled. <p>Check drive dimensioning</p> <ul style="list-style-type: none"> ● When C0064 = 95 %, the reduction of the maximum current is cancelled. The warning is cancelled. ● NOTE: Operation at increased rated power (120 % overload capacity) is not possible. <ul style="list-style-type: none"> ● Check the motor cable connection for correct phase relation ● If possible, operate the motor with deactivated feedback (C0025 = 1) and check the direction of rotation of the motor. ● See also 31

Display	Error number x = 0: TRIP x = 1: Message x = 2: Warning	Error	Cause	Remedy
OH	x050	Heatsink temperature is higher than the value set in the controller	Ambient temperature $T_u > 40\text{ °C}$ or 50 °C	<ul style="list-style-type: none"> Allow controller to cool and ensure better ventilation Check ambient temperature in the control cabinet
			Heatsink very dirty	Clean heatsink
			Wrong mounting position	Change mounting position
OH3	x053	Motor temperature is higher than the value set in the controller	Motor too hot because of excessive current or frequent and too long acceleration	Check drive dimensioning
			No KTY is connected to X8	Connect KTY or switch off monitoring (C0583 = 3)
OH4	x054	Heatsink temperature is higher than the value set in C0122	Ambient temperature $T_u > 40\text{ °C}$ or 50 °C .	<ul style="list-style-type: none"> Allow controller to cool and ensure better ventilation Check ambient temperature in the control cabinet
			Heatsink very dirty	Clean heatsink
			Wrong mounting position	Change mounting position
			The value entered in C0122 is too low	Enter higher value
OH7	x057	Motor temperature is higher than the value set in C0121	Motor too hot because of excessive current or frequent and too long acceleration	Check drive dimensioning
			No KTY is connected to X8	Connect KTY or switch off monitoring (C0584 = 3)
			The value entered in C0121 is too low	Enter higher value
OH8	x058	PTC at terminals T1, T2 indicates motor overheating	Motor too hot because of excessive current or frequent and too long acceleration	Check drive dimensioning
			Terminals T1, T2 are not assigned	Connect PTC or thermal contact or switch off monitoring (C0585=3)
OU	x020	Overvoltage in the DC bus	Only for variants V210, V240, V270, V300: <ul style="list-style-type: none"> Wrong values in C0173 Wrong values in C0174 	<ul style="list-style-type: none"> Set correct values in C0173 Set correct values in C0174
PEr	x074	Program fault	An error has been detected in the program flow. The parameter set 1 is loaded automatically. Parameter data which has been changed and not has been saved, will get lost.	Contact Lenze
PI	x079	Initialisation error	<ul style="list-style-type: none"> A fault was detected during transfer of parameter sets between the controllers Parameter set does not match the controller 	Correct parameter set
PRO	x075	Parameter set error	Error while loading a parameter set. The parameters saved do not match the software version of the controller. CAUTION! The Lenze setting is loaded automatically.	<ul style="list-style-type: none"> Correct parameter set Save all parameter sets with C0003 and reset the fault message by mains switching
PR1 PR2 PR3 PR4	x072 x073 x077 x078	Parameter set error	<ul style="list-style-type: none"> Fault while loading a parameter set The transmission of parameter sets with keypad XT has been interrupted (e.g. by an early disconnection of the keypad XT) CAUTION! The Lenze setting is loaded automatically.	Set the required parameters and save them with C0003
Sd3	x083	Encoder error at X9	Cable interrupted	Check cable for wire breakage

Display	Error number x = 0: TRIP x = 1: Message x = 2: Warning	Error	Cause	Remedy
			Pin X9/8 is not assigned	Assign pin X9/8 with 5 V or switch off monitoring (C0587 = 3)
Sd5	x085	Encoder at X6/1, X6/2 is defective	Current at X6/1, X6/2 < 2 mA	<ul style="list-style-type: none"> • Check cable for wire breakage • Check encoder
Sd6	x086	Sensor error at X8	KTY at X8 indicates undefined values	<ul style="list-style-type: none"> • Check supply cable for firm connection • Switch off monitoring with C0594 = 3 if necessary

4 Troubleshooting and fault elimination

System error messages
Resetting system error messages

4.5.2 Resetting system error messages

Eliminate the cause of TRIP fault message

After you have eliminated the cause of a TRIP fault message, you must reset the fault message with the command "TRIP reset". Only then the drive restarts.



Note!

A TRIP fault message can have several causes. Only if all causes of the TRIP have been eliminated, the TRIP reset can be executed.

TRIP reset

- ▶ Keypad XT: Press **STOP**. Then press **RUN** to enable the controller.
- ▶ Fieldbus module: Set C0043 = 0
- ▶ Control word: C0135
- ▶ Terminal: X5/E5 = HIGH
- ▶ Control word via AIF
- ▶ Control word via system bus (CAN)

Mains switching always executes TRIP reset.

Codes for parameter setting

Code		Possible settings		IMPORTANT	
No.	Name	Lenze	Selection		
C0043	Trip reset	0	0	no/trip reset	Reset actual error
			1	trip active	There is a TRIP error



© 04/2010



Lenze Automation GmbH
Hans-Lenze-Str. 1
D-31855 Aerzen
Germany



+49 (0)51 54 / 82-0



+49 (0)51 54 / 82 - 28 00



Lenze@Lenze.de



www.Lenze.com

Service

Lenze Service GmbH
Breslauer Straße 3
D-32699 Extertal
Germany



00 80 00 / 24 4 68 77 (24 h helpline)



+49 (0)51 54 / 82-11 12



Service@Lenze.de

EDKVF93-04 ■ 13334534 ■ EN ■ 2.0 ■ TD23

10 9 8 7 6 5 4 3 2 1